



扫一扫获取更多信息...

XINLIANG

聚氨酯成套设备

Complete Equipment For Polyurethane

电话(Tel):0574-62853033 62853056

传真(Fax):0574-62853032

手机(Mobile): 销售 13968221920(微信同号)

售后 13645840222

whatsapp:+86 13867881815

邮箱(E-MAIL):xinliangjixie@163.com

邮编(P.C):315455

网址(Website): <http://www.xinliangjixie.com>

国外(abroad) :<http://www.xinliang-pumachine.com>

地址: 浙江省宁波余姚市阳明街道康山工业园区

Add: Zhejiang Yuyao City Yangming Street Kangshan Industrial District

因技术研究提升, 本公司有权修改相关技术参数, 恕不另行通知。

XINLIANG

聚氨酯成套设备

Complete Equipment For Polyurethane

(国内) <http://www.xinliangjixie.com> (国外) <http://www.xinliang-pumachine.com>



宁波鑫亮机械有限公司

NINGBO XIN LIANG MACHINERY CO.,LTD



XINLIANG 宁波鑫亮机械有限公司
NINGBO XIN LIANG MACHINERY CO., LTD.

鑫亮机械掌握核心技术
XIN LIANG MECHANICAL GRASP CORE TECHNOLOGY

WINCOOPERATION
合作共赢



BRIEF INTRODUCTION

企业简介

宁波鑫亮机械有限公司位于浙江省宁波余姚市，是长江三角洲经济圈南翼环杭州湾地区上海、杭州、宁波三大都市经济金三角的中心，区位和交通优势十分明显。

宁波鑫亮机械有限公司专业从事聚氨酯发泡设备研发、制造及技术服务的专业型高科技企业，拥有十多年专业设计经验的研发人员，熟悉国内外聚氨酯发泡设备先进技术。

公司依托浙江雄厚的工业基础和良好的区位优势，走“科技创新，追求专业化”的发展之路，专注于为聚氨酯行业用户提供量身定制的最优化解决方案。

我们始终以满足顾客需求为中心，以技术，品牌，服务为核心，根据不同用户的生产规模和需求，我们可提供由简单到复杂，由适用小规模生产的经济实用的单机及固定式加工设备，到满足高效率、大批量生产的高度自动化的成套聚氨酯设备。

我厂的主要产品包括，各类聚氨酯高压发泡机、中间罐、龙门架发泡生产线、转盘发泡生产线、保温建材发泡生产线及，并长期提供国产及进口各类高压发泡机零部件供应等，相关产品已广泛应用于冰箱、冷柜、消毒柜、电热水器、制冰机、空调、太阳能、车库门、防盗门、玩具、工程屋面墙体隔音、保温、屋顶隔热、防寒、管道、汽车内外饰件、保温建材、家具、工艺品及运动器材等。还提供系列环戊烷，进行无氟替代设备改造升级，同时长期免费为用户提供前期项目规划，技术咨询及技术服务。

鑫亮机械始终坚持“以人为本，用户至上，诚信经营，合作双赢”的经营理念，铭记“求实创新，拼搏进取”的企业精神，致力于为广大用户提供优质的产品和一流的售后服务。鑫亮机械生产的高压发泡机远销于国外市场于西班牙，澳大利亚，埃及，摩洛哥，整个国内都有鑫亮机械提供的设备。

办公室 Office

Ningbo Xin Liang Machinery Co., Ltd. is located in Yuyao ningbo City, Zhejiang Province, is the center of the southern wing of the Yangtze River Delta economic circle around Hangzhou Bay to Shanghai, Hangzhou, Ningbo, three metropolitan economy in the Golden Triangle, location and transportation advantages are clear.

Ningbo Xin Liang Machinery Co., Ltd. specializes in polyurethane foam equipment research and development, high-tech enterprise specializing in manufacturing and technical services, has 10 years of professional experience in the design of R & D personnel, familiar with the domestic and foreign advanced technology of polyurethane foam equipment. The company relies on a strong industrial base in Zhejiang and good geographical advantage and take the "scientific and technological innovation, the pursuit of professional" development path, focused on providing tailored solutions for optimizing the polyurethane industry users.

We have always to meet customer demand as the center, technology, brand, serve as the core, depending on the user's production scale and needs, we can provide from simple to complex, from small-scale production of suitable economical and practical stand-alone and stationary processing equipment, to meet the high efficiency, highly automated mass production of complete sets of polyurethane equipment.

I plant's main products include various types of high-pressure polyurethane foam machine, intermediate tanks, gantry foam production line, dial foam production lines, production lines and foam insulation materials, and provide long-term domestic and imported all kinds of high pressure foaming machine parts supply and other related products have been widely used in refrigerators, freezers, disinfection cabinet, electric water heaters, ice machines, air conditioning, solar energy, garage doors, security doors, toys, engineering roof wall insulation, insulation, roof insulation, cold, pipeline, automotive interior and exterior parts, insulation materials, furniture, crafts and sports equipment. Also provides a series of cyclopentane, conducted freon replacement equipment upgrading, while long-term free to provide users with pre-project planning, technical advice and technical services.

Xin Liang machinery always adhere to the "people-oriented, customer first, integrity management, cooperation and win-win" business philosophy, bearing in mind the "innovation, hard work ahead," the entrepreneurial spirit, commitment to provide customers with quality products and quality service. Xin Liang mechanical production of high pressure foaming machine exported to foreign markets in Spain, Australia, Egypt, Morocco, the whole country has provided Xin Liang equipment and machinery.



精益化生产车间



ADVANCED PRODUCTION FLOWS

SALES NETWORK

销售网络

鑫亮机械长期潜心于营销网络的建设。如今，精耕细作的营销网络已遍布全国所有省、市。长期稳定的合作和可持续发展的共同目标，使得营销网络具有极强的凝聚力和稳定性；完善的售中和售后服务也使营销网络的竞争力持续提升。

Xinliang machinery has been focusing on the construction of marketing network for a long time. Today, the intensive marketing network has spread throughout all provinces and cities across the country. Long-term stable cooperation and sustainable common development make marketing network have strong cohesion and stability. Perfect sales and after-sales service also make the competitiveness of marketing network continuously improved.



普通高压发泡机系列 Ordinary high pressure foaming machine series	01-08
环戊烷高压发泡机系列 Cyclopentane high pressure foaming machine series	09-12
环戊烷静态预混系统 Cyclopentane static premixing system	13-14
发泡模架 Foaming formwork	15-16
转盘发泡线 Turntable foaming line	17-18
发泡环形线 Foamed loop	19-20
龙门、悬挂发泡线 Gantry, hanging foam line	21
35立方米卧式储罐 35 cubic meters horizontal storage tank	22
中间供料储罐 Foaming intermediate feed storage tank	22
发泡机辅助设备 Foaming machine auxiliary equipment	23-24
聚氨酯高压发泡机工作流程图 Polyurethane high pressure foaming machine work flow chart	25-26
发泡机配件 Foaming machine accessories	27-29

发泡机配置介绍 Foaming machine configuration introduction	30
客户案例 Customer case	31-43
应用领域 Application field:	44-45
售后服务 After sales service	46

CONTENTS

目录

(国内) <http://www.xinliangjixie.com> (国外) <http://www.xinliang-pumachine.com>

普通系列高压发泡机
ORDINARY SERIES HIGH PRESSURE
FOAMING MACHINE

HB二组份高压发泡机带机械手



普通系列高压发泡机
ORDINARY SERIES HIGH PRESSURE
FOAMING MACHINE

HB二组份高压发泡机带六轴机器人



普通系列高压发泡机 ORDINARY SERIES HIGH PRESSURE FOAMING MACHINE

HB二组份高压发泡机



产品名称:HB二组份高压发泡机

PRODUCT NAME: HB TWO-COMPONENT
HIGH PRESSURE FOAMING MACHINE

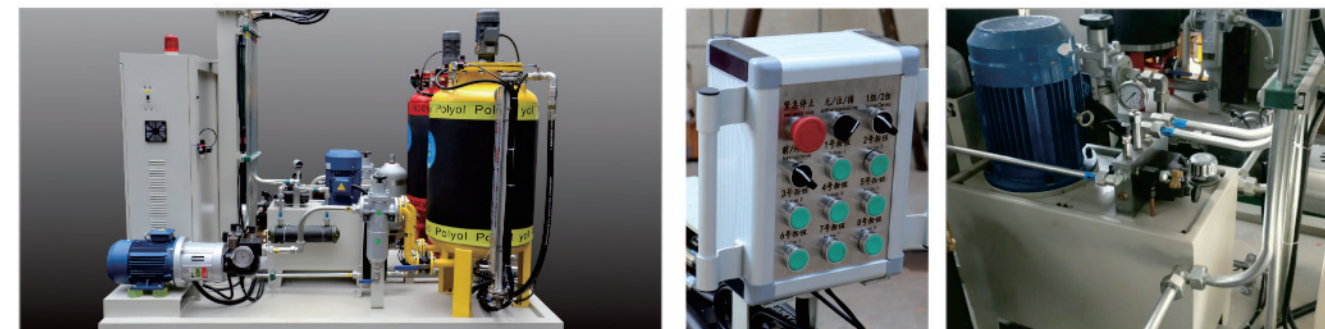

详细介绍 DETAILS INTRODUCTION

HB-20/40/100/200/300/400系列发泡机是我厂最新一代二组分高压发泡机,它采用模块化设计方式,根据顾客的具体需求而搭建成具有最优性价比的机器,适用范围极为广泛。机器广泛适用于方向盘、汽车坐垫等汽车内饰件、冰箱保温层、保温建材等所有聚氨酯发泡产品。

HB-20/40/100/200/300/400 series high pressure foaming machine is the latest generation of two-component factory high pressure foaming machine in our factory. It has a modular design, based on the customers specific needs and take into the optimal price/performance of the machine, Has wide scope. Machines are widely used in the steering wheel, car seat and other car interior parts, refrigerator insulation, polyurethane foam insulation materials and all other products.

技术参数 TECHNICAL PARAMETERS

型号	组分比例 A:B	料温 A/B	输出量A+B克/秒 最小/最大	料罐容积 升/罐	功率 千瓦
HB-20	可调	可调	30/300	300	18
HB-40	可调	可调	60/650	300	23
HB-100	可调	可调	130/1350	300	32
HB-200	可调	可调	250/2500	500	55
HB-300	可调	可调	500/5000	500	100
HB-400	可调	可调	1000/10000	1000	100

MODEL	Component ratioA:B	Material temperatureA/B	OutputA+B g/secondmin/max	Material filling volumeL/volume	power(KW)
HB-20	ADJUSTABLE	ADJUSTABLE	30/300	300	18
HB-40	ADJUSTABLE	ADJUSTABLE	60/650	300	23
HB-100	ADJUSTABLE	ADJUSTABLE	130/1350	300	32
HB-200	ADJUSTABLE	ADJUSTABLE	250/2500	500	55
HB-300	ADJUSTABLE	ADJUSTABLE	500/5000	500	100
HB-400	ADJUSTABLE	ADJUSTABLE	1000/10000	1000	100

普通系列高压发泡机 ORDINARY SERIES HIGH PRESSURE FOAMING MACHINE

HB二组份轨道移动式高压发泡机



产品名称:HB二组份轨道移动式高压发泡机

PRODUCT NAME: HB TWO-COMPONENT
ORBITAL MOBILE HIGH PRESSURE
FOAMING MACHINE



详细介绍 DETAILS INTRODUCTION

HB-20/40/100/200/300/400系列发泡机是我厂最新一代二组分高压发泡机,它采用模块化设计方式,根据顾客的具体需求而搭建成具有最优性价比的机器,适用范围极为广泛。机器广泛适用于方向盘、汽车坐垫等汽车内饰件、冰箱保温层、保温建材等所有聚氨酯发泡产品。

HB-20/40/100/200/300/400 series high pressure foaming machine is the latest generation of two-component factory high pressure foaming machine in our factory, It has a modular design, based on the customers specific needs and take into the optimal price/performance of the machine, Has wide scope. Machines are widely used in the steering wheel, car seat and other car interior parts, refrigerator insulation, polyurethane foam insulation materials and all other products.

技术参数 TECHNICAL PARAMETERS

型号	组分比例 A:B	料温 A/B	输出量A+B克/秒 最小/最大	料罐容积 升/罐	功率 千瓦
HB-20	可调	可调	30/300	300	18
HB-40	可调	可调	60/650	300	23
HB-100	可调	可调	130/1350	300	32
HB-200	可调	可调	250/2500	500	55
HB-300	可调	可调	500/5000	500	100
HB-400	可调	可调	1000/10000	1000	100

MODEL	Component ratioA:B	Material temperatureA/B	OutputA+B g/secondmin/max	Material filling volumeL/volume	power(KE)
HB-20	ADJUSTABLE	ADJUSTABLE	30/300	300	18
HB-40	ADJUSTABLE	ADJUSTABLE	60/650	300	23
HB-100	ADJUSTABLE	ADJUSTABLE	130/1350	300	32
HB-200	ADJUSTABLE	ADJUSTABLE	250/2500	500	55
HB-300	ADJUSTABLE	ADJUSTABLE	500/5000	500	100
HB-400	ADJUSTABLE	ADJUSTABLE	1000/10000	1000	100

普通系列高压发泡机 ORDINARY SERIES HIGH PRESSURE FOAMING MACHINE

HB三组份高压发泡机



产品名称:HB三组份高压发泡机

PRODUCT NAME: HB THREE-COMPONENT HIGH PRESSURE FOAMING MACHINE



详细介绍 DETAILS INTRODUCTION

HB-20/40/100/200/300/400双色双密度高压发泡机，混合头采用L型分别有两个独立的混合室，最终有一个出口灌注。针对汽车内外饰件，家具行业，管道支架保温，自结皮工艺专用件等，可满足市场的需求。

HB-20/40/100/200/300/400-color double-density high-pressure foaming machine, mixing head, respectively, using the L-shaped two separate mixing chamber, and ultimately there is an outlet perfusion. Interior and exterior parts for the automotive and furniture industries, pipe Road bracket insulation, self-skinning technology-specific pieces to meet the needs of the market.

技术参数 TECHNICAL PARAMETERS

型号	组分比例 A:B	料温 A/B	输出量A+B克/秒 最小/最大	料罐容积 升/罐	功率 千瓦
HB-20	可调	可调	30/300	300	18
HB-40	可调	可调	60/650	300	23
HB-100	可调	可调	130/1350	300	32
HB-200	可调	可调	250/2500	500	55
HB-300	可调	可调	500/5000	500	100
HB-400	可调	可调	1000/10000	1000	100

MODEL	Component ratioA:B	Material temperatureA/B	OutputA+B g/secondmin/max	Material filling volumeL/volume	power(KE)
HB-20	ADJUSTABLE	ADJUSTABLE	30/300	300	18
HB-40	ADJUSTABLE	ADJUSTABLE	60/650	300	23
HB-100	ADJUSTABLE	ADJUSTABLE	130/1350	300	32
HB-200	ADJUSTABLE	ADJUSTABLE	250/2500	500	55
HB-300	ADJUSTABLE	ADJUSTABLE	500/5000	500	100
HB-400	ADJUSTABLE	ADJUSTABLE	1000/10000	1000	100

环戊烷系列高压发泡机

CYCLOPENTANE SERIES HIGH PRESSURE FOAMING MACHINE

HA单系统环戊烷高压发泡机



产品名称:HA单系统环戊烷高压发泡机

PRODUCT NAME: HA SINGLE SYSTEM CYCLOPENTANE HIGH PRESSURE FOAMING MACHINE

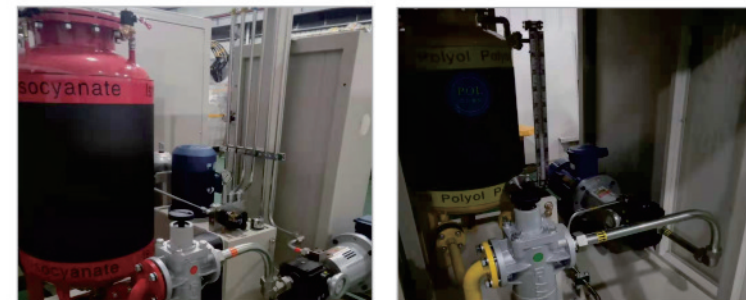

详细介绍 DETAILS INTRODUCTION

HA-20/40/100/200/300/400系列环戊烷高压发泡机广泛应用于家电冰箱、冷柜、热水器、消毒柜绝热层、空调夹心板的无氟发泡，真正适合该行业以及冰箱出口国外市场的环保要求。

HA - 20/40/100/200/300/400 series cyclopentane high pressure foaming machine is widely used in household appliances refrigerators, freezers, water heaters, disinfection cabinet, thermal barrier, air conditioner cfc-free foam sandwich panels, really suitable for the industry and environmental requirements of the refrigerator export markets abroad.

技术参数 TECHNICAL PARAMETERS

型号	组分比例 A:B	料温 A/B	输出量A+B克/秒 最小/最大	料罐容积 升/罐	功率 千瓦
HA-20	可调	可调	30/300	300	18
HA-40	可调	可调	60/650	300	23
HA-100	可调	可调	130/1350	300	32
HA-200	可调	可调	250/2500	500	55
HA-300	可调	可调	500/5000	500	100
HA-400	可调	可调	1000/10000	1000	100

MODEL	Component ratio A:B	Material temperature A/B	Output A+B g/second/min/max	Material filling volume L/volume	power (KE)
HA-20	ADJUSTABLE	ADJUSTABLE	30/300	300	18
HA-40	ADJUSTABLE	ADJUSTABLE	60/650	300	23
HA-100	ADJUSTABLE	ADJUSTABLE	130/1350	300	32
HA-200	ADJUSTABLE	ADJUSTABLE	250/2500	500	55
HA-300	ADJUSTABLE	ADJUSTABLE	500/5000	500	100
HA-400	ADJUSTABLE	ADJUSTABLE	1000/10000	1000	100

环戊烷系列高压发泡机

CYCLOPENTANE SERIES HIGH PRESSURE FOAMING MACHINE

HA双系统环戊烷高压发泡机带轨道



产品名称:HA双系统环戊烷高压发泡机

PRODUCT NAME: HA DUAL SYSTEM CYCLOPENTANE HIGH PRESSURE FOAMING MACHINE



详细介绍 DETAILS INTRODUCTION

HA-20/40/100/200/300/400环戊烷双系统高压发泡机,两把混合头同时工作,互不干涉,高压发泡机广泛应用于家电冰箱、冷柜、热水器、消毒柜绝热层、空调夹心板的无氟发泡,真正适合该行业以及冰箱出口国外市场的环保要求。

HA-20/40/100/200/300/400 cyclopentane dual system high pressure foaming machine, two mixing heads simultaneously, mutual non-interference, high-pressure foaming machine is widely used in home appliances refrigerators, freezers, water heaters, disinfection cabinet insulation, CFC-free air conditioning foam sandwich panels, really suitable for the industry as well as export markets abroad refrigerator environmental requirements.

技术参数 TECHNICAL PARAMETERS

型号	组分比例 A:B	料温 A/B	输出量A+B克/秒 最小/最大	料罐容积 升/罐	功率 千瓦
HA-20	可调	可调	30/300	300	18
HA-40	可调	可调	60/650	300	23
HA-100	可调	可调	130/1350	300	32
HA-200	可调	可调	250/2500	500	55
HA-300	可调	可调	500/5000	500	100
HA-400	可调	可调	1000/10000	1000	100

MODEL	Component ratio A:B	Material temperature A/B	Output A+B g/second/min/max	Material filling volume L/volume	power (KE)
HA-20	ADJUSTABLE	ADJUSTABLE	30/300	300	18
HA-40	ADJUSTABLE	ADJUSTABLE	60/650	300	23
HA-100	ADJUSTABLE	ADJUSTABLE	130/1350	300	32
HA-200	ADJUSTABLE	ADJUSTABLE	250/2500	500	55
HA-300	ADJUSTABLE	ADJUSTABLE	500/5000	500	100
HA-400	ADJUSTABLE	ADJUSTABLE	1000/10000	1000	100

环戊烷预混系统
CYCLOPENTANE PREMIX SYSTEM



环戊烷及245FA静态预混系统
Cyclopentane And 245fa Static Premix System



混合前聚醚储存系统
Pre-mixed polyether storage system



静态混合室
Static mixing room



聚醚+环戊烷混合后储存系统
Polyether + cyclopentane mixed storage system



环戊烷地罐
Cyclopentane can

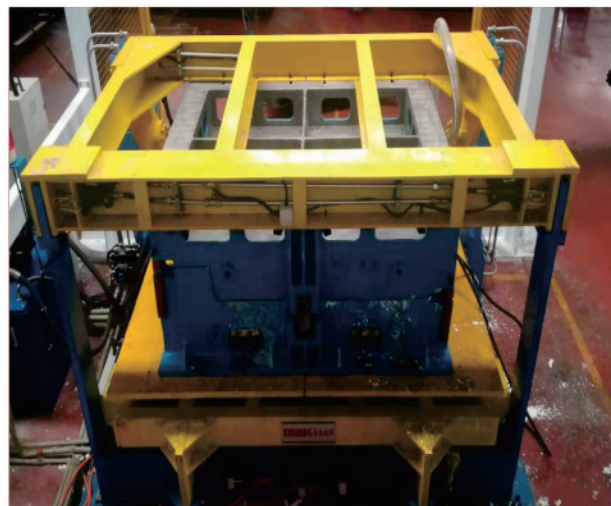

液压翻转模架
Hydraulic flip formwork



液压发泡模架
Hydraulic foaming formwork



汽车前围发泡模架
Automobile front wall foaming formwork



自动发泡浇注系统
Automatic foaming and pouring system



汽车地毯发泡自动浇注
Car carpet foaming automatic pouring

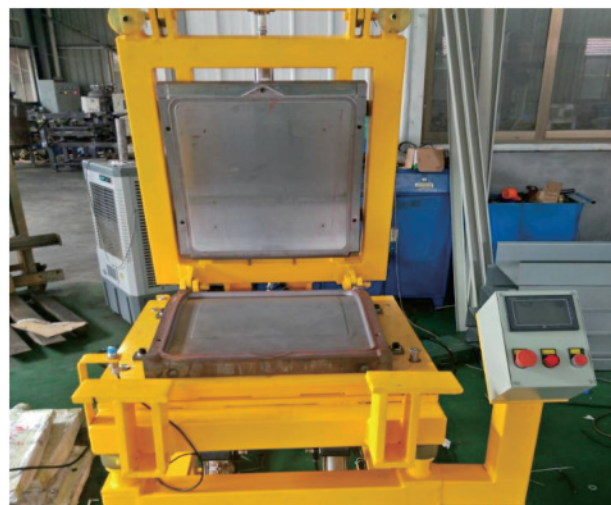

自结皮椅子发泡模架
Self-skinning chair foaming formwork



汽车发动机罩盖发泡模架
Automobile engine cover foaming formwork



发泡模架
Foam line

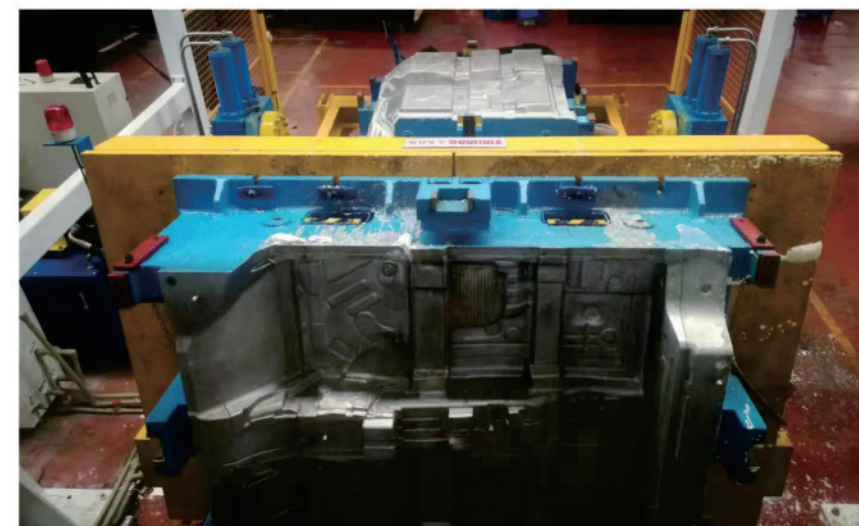

汽车地毯发泡自动浇注
Car carpet foaming automatic pouring



液压翻转模架
Hydraulic flip formwork



转盘发泡线 Turntable foaming line

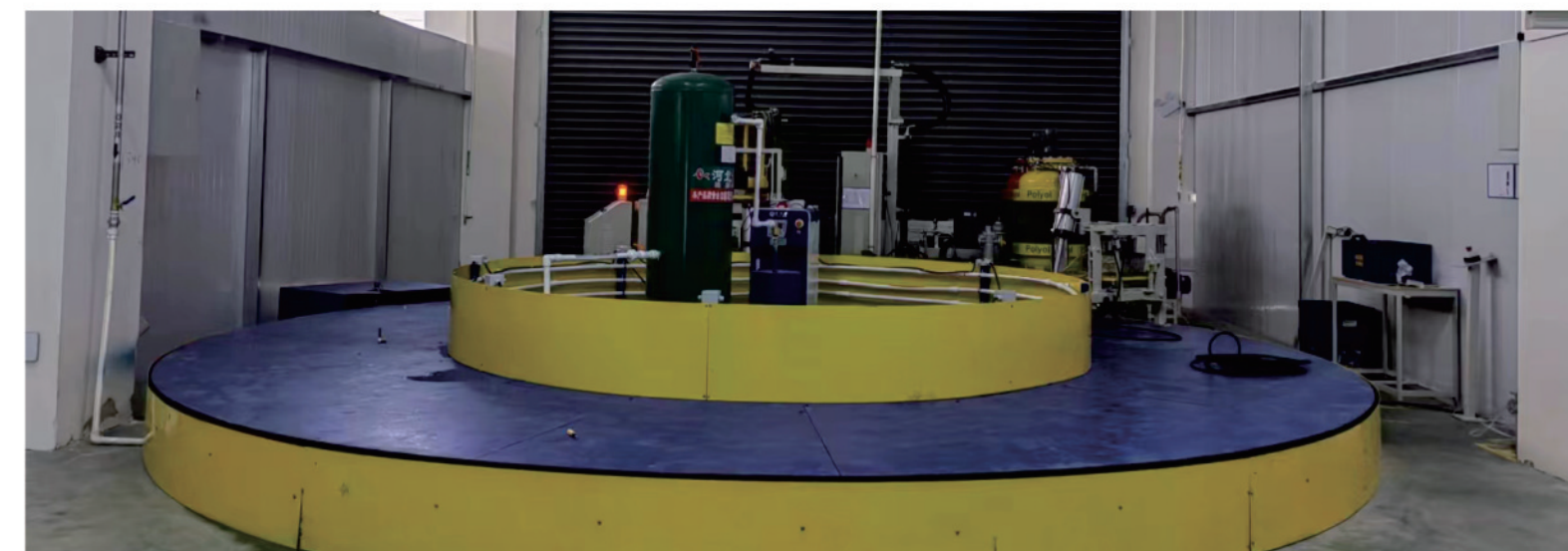



70工位全自动开合模发泡环形线
70 station automatic opening and closing mold foam ring line

70工位全自动开合模发泡环形线
70 station automatic opening and closing mold foam ring line





H 型龙门架发泡线 H type gantry foaming line

详细介绍：
简易直线发泡线是我公司为加工生产特种产品设计的发泡生产线，它满足于在发泡机不动的前提下混合头由线体控制移动在指定可控范围内灌注发泡，具有生产效率高、劳动强度小、环境污染少、多品种柔性生产等特点。

35立方米卧式储罐

35 CUBIC HORIZONTAL TANK



35立方米卧式储罐 35 cubic meters horizontal storage tank

中间供料储罐 Intermediate supply tank



foam



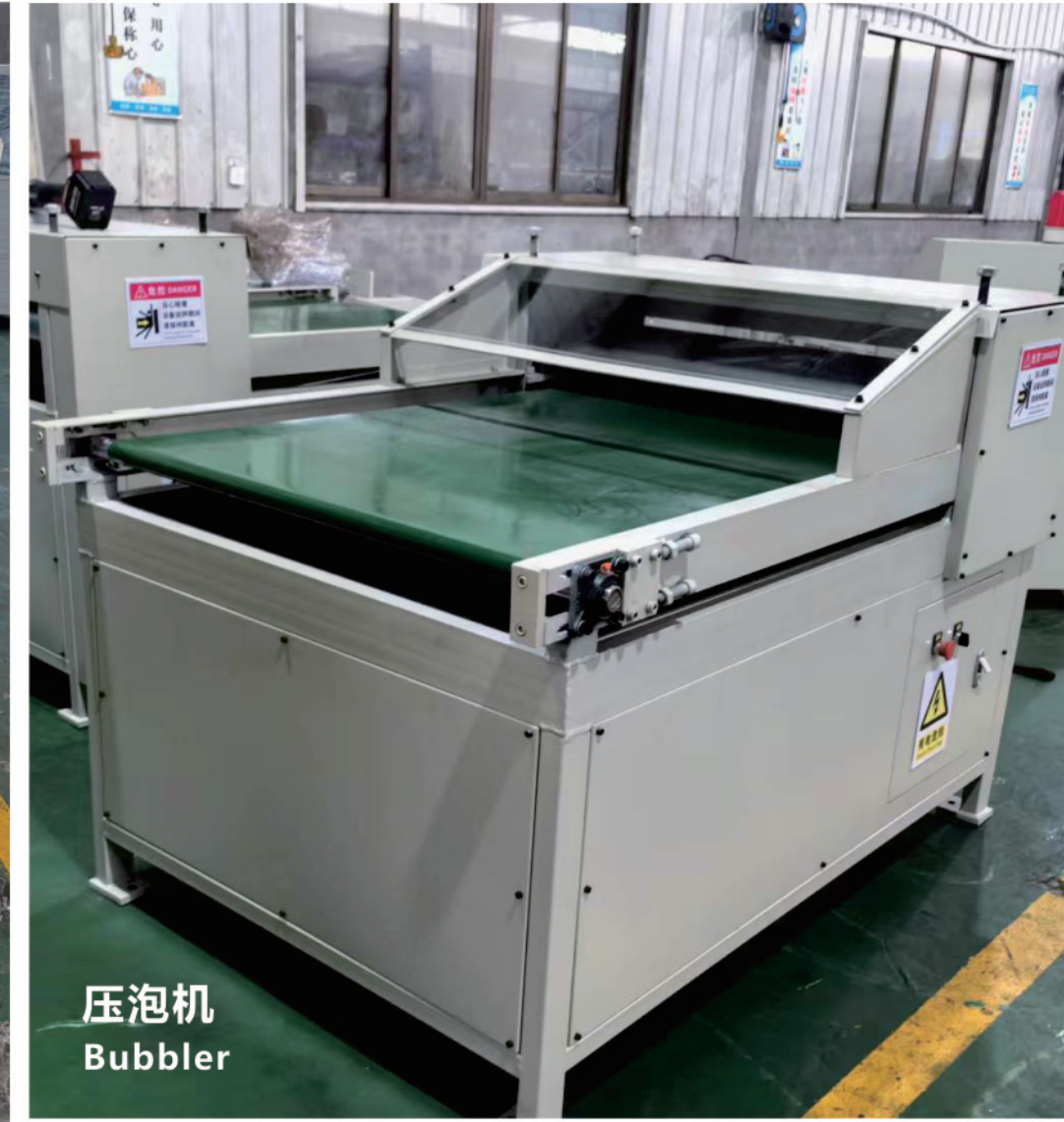
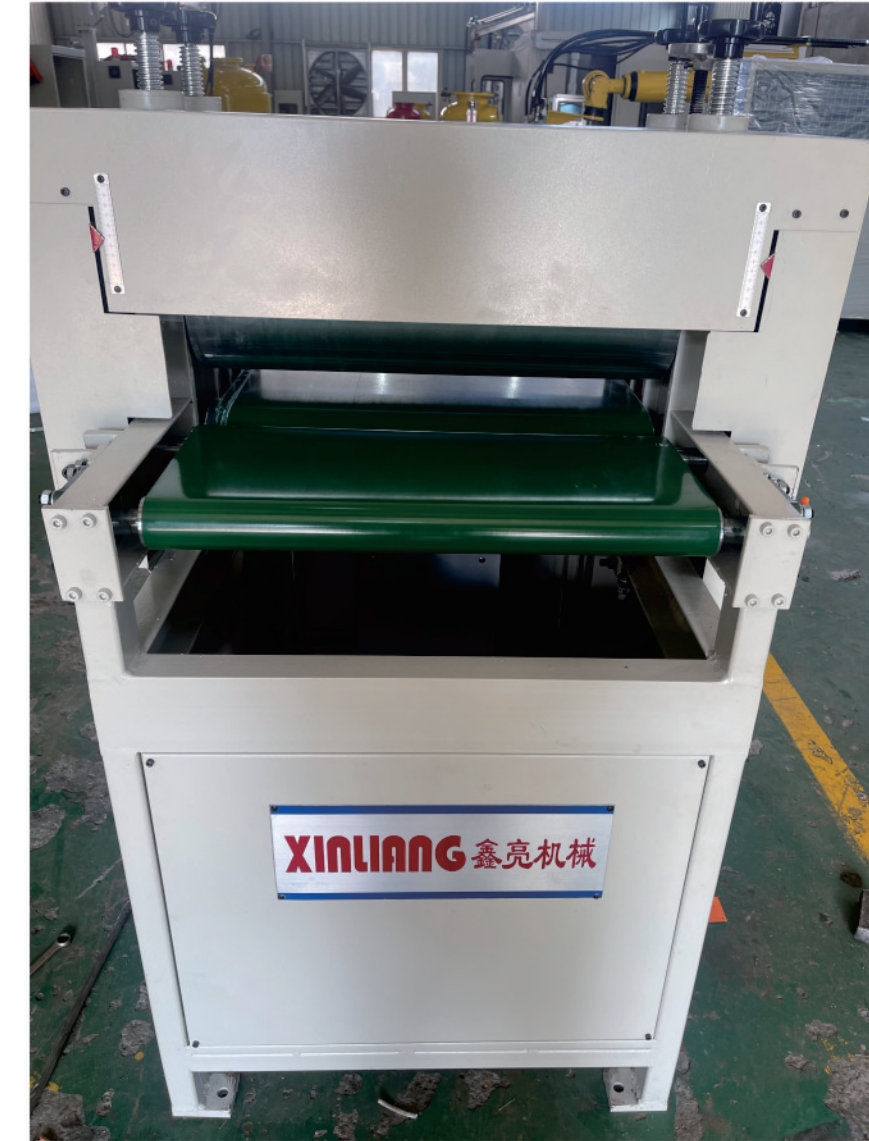

真空滚轮 Vacuum roller

压泡机
Bubbler

聚氨酯高压发泡机工作流程图

Pu Metering Machines Adjustment Rangel

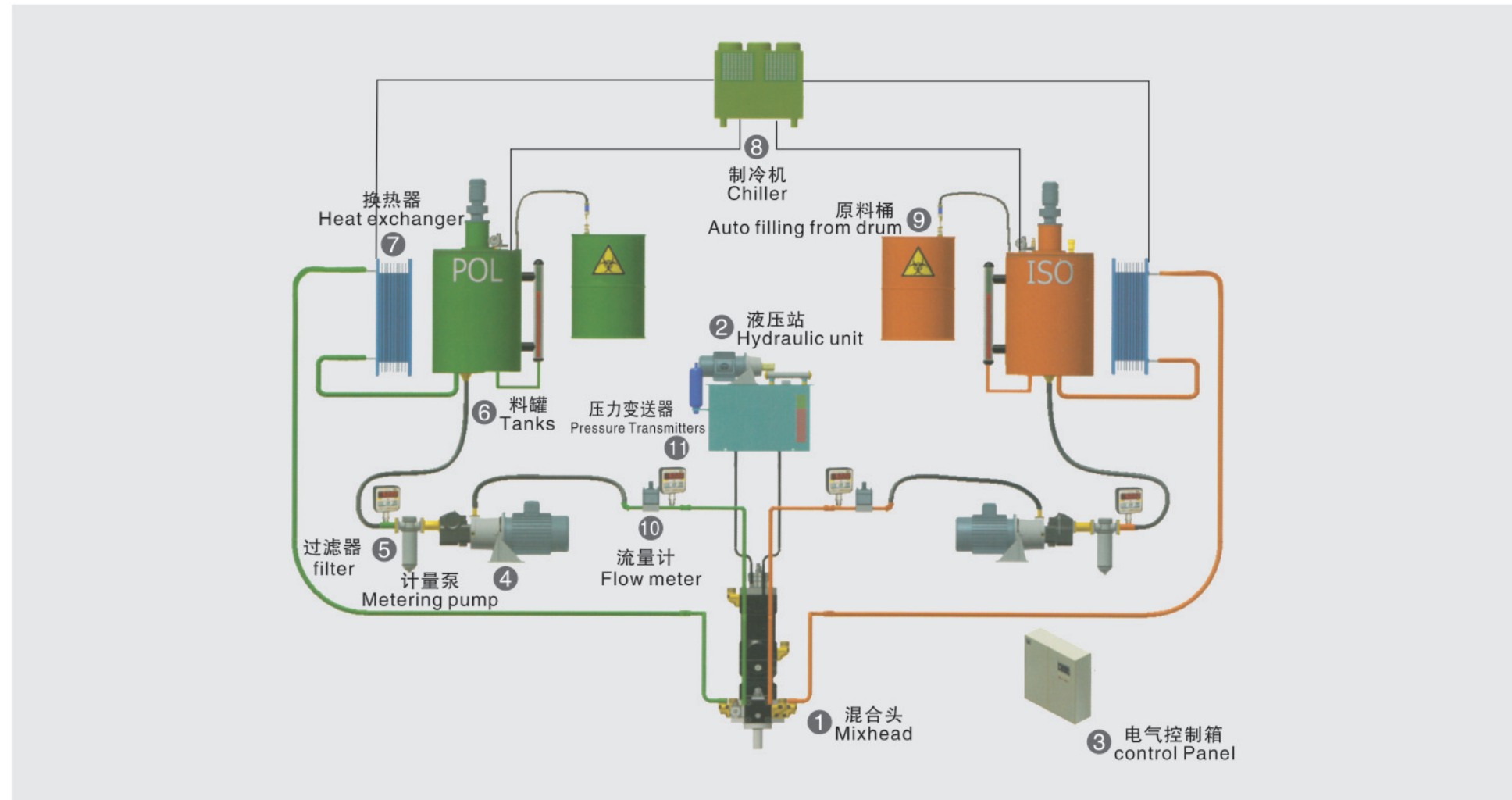

高压混合头混合循环动作过程

High Pressure Head Mix Circulation Process

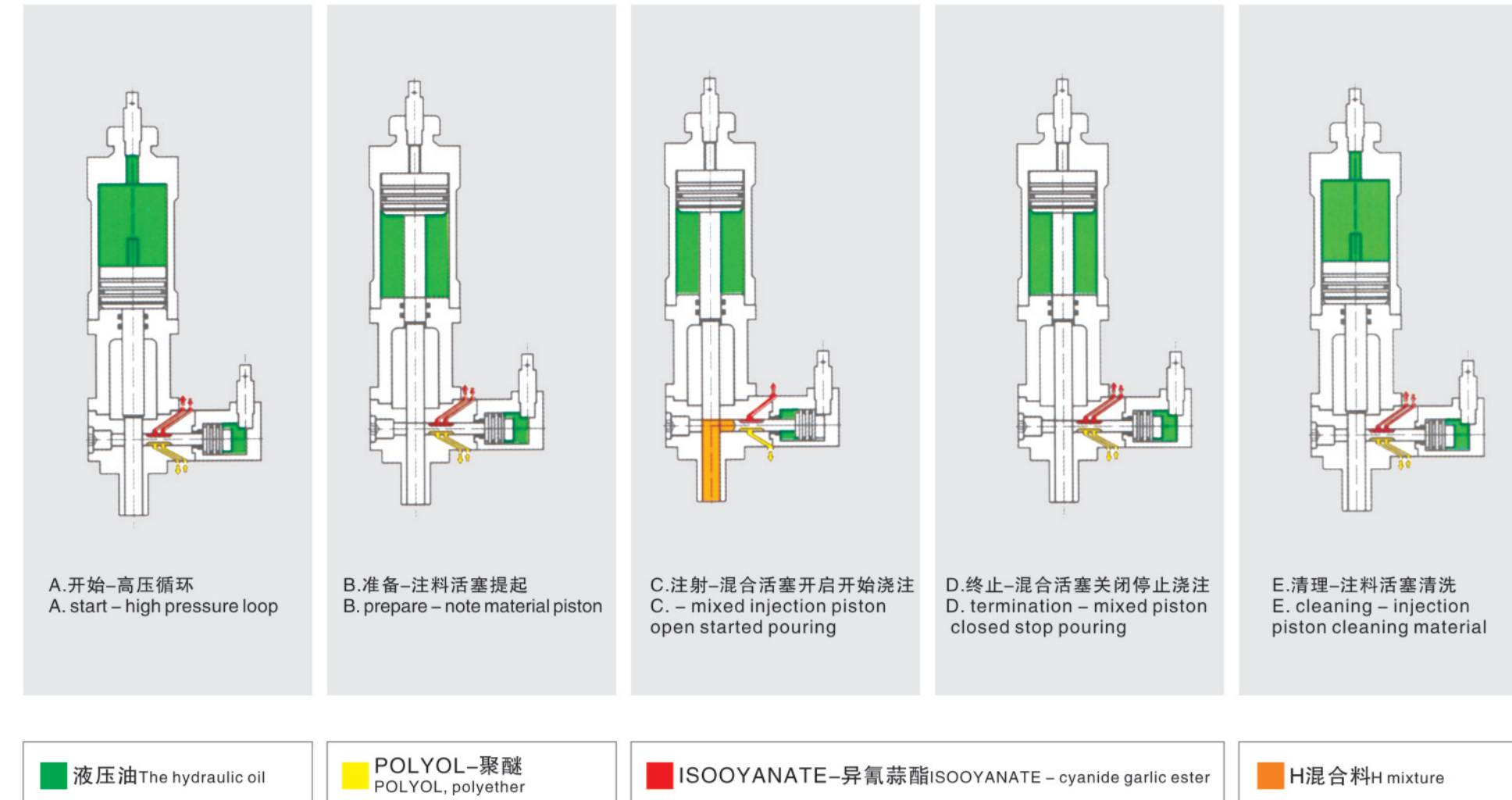

高压混合头混合循环动作过程
High Pressure Head Mix Circulation Process



「L」型双斜角双感应混合头
L-type dual bevel & dual induction efficiency mix head

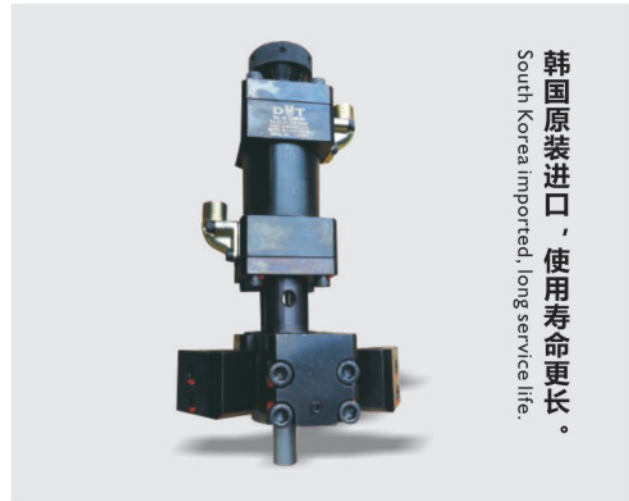

韩国原装进口，使用寿命更长。
South Korea imported, long service life.

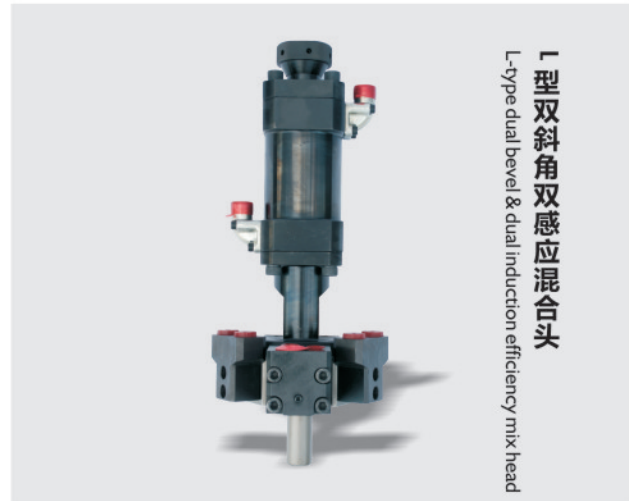

「L」型双斜角双感应混合头
L-type dual bevel & dual induction efficiency mix head

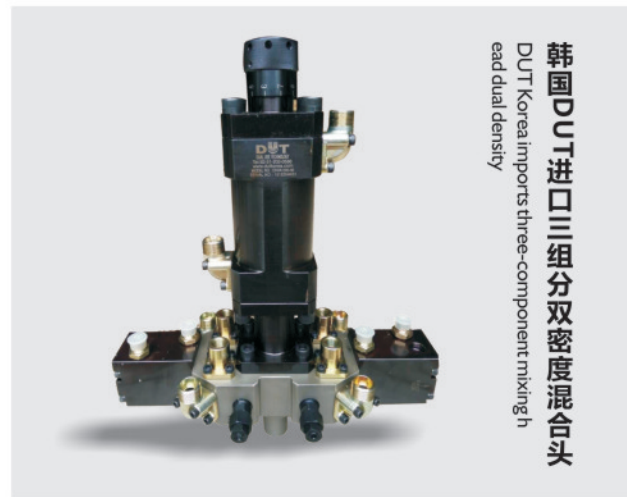

韩国DUT进口三组分双密度混合头
DUT Korea imports three-component mixing head dual density



三组分双密度混合头
Three components of the double density mixing head

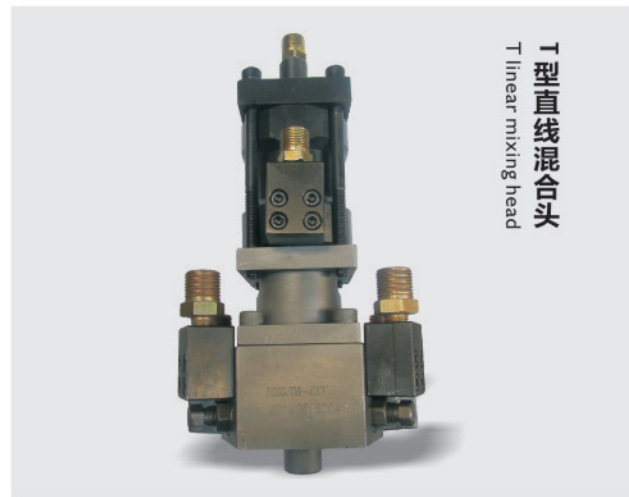

「T」型直线混合头
T linear mixing head

高压发泡机计量泵
Metering pump high-pressure foaming machine



德国力士乐原装A7VK系列变量计量泵
Metering pump Germany Rexroth variable original A7VK series



A2VK系列变量计量泵
Metering pump A2VK series variable

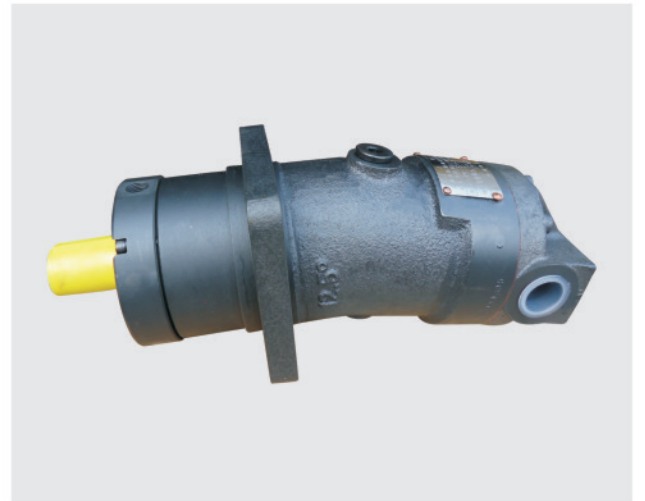

A2FK系列高压定量计量泵
Rexroth A2FK series high pressure quantitative metering pump

磁性联轴器 Magnetic coupling



安装说明
磁性联轴器
Installation instructions
Magnetic coupling

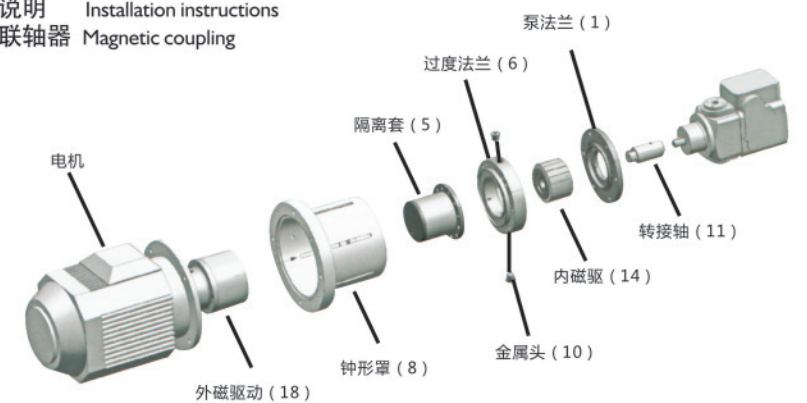

发泡机配件 Foaming Machine Accessories



冷热水机
Hot and cold water machine



模温机
Mold temperature machine



德国KRACHT进口流量计
German KRACHT flowmeter



自清洗过滤器
Self-cleaning filter

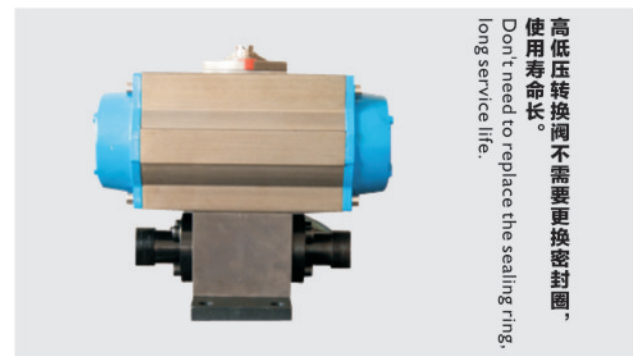

高低压转换不需要更换密封圈，使用寿命长。
Don't need to replace the sealing ring, long service life.

发泡机配置介绍

Foaming machine configuration is introduced



100L优质碳钢油箱，隔离双油箱设计
10L预充氮蓄能器溢流阀，安全阀，手动泄压阀压力变送器
100L tank, separate design and fillet inside. 4L accumulator, 100Bar Nitrogen Pre-Charged Pressure relieve valve, manual release

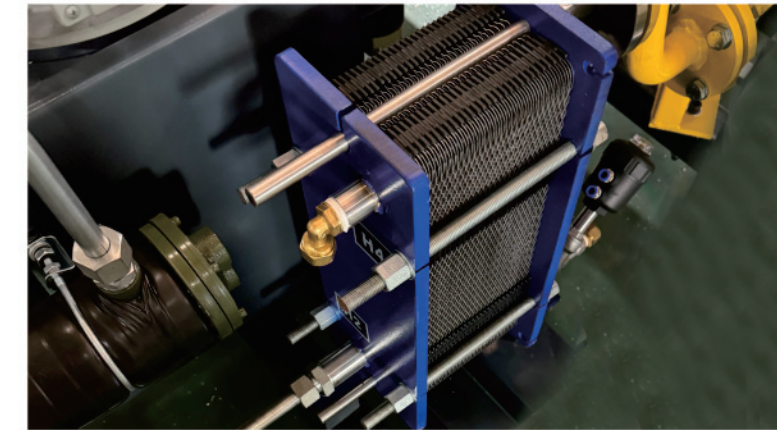

板式换热器,冷却效果更佳。
Plate heat exchanger, the cooling effect is better.



所有高压发泡机都采用10寸大触摸屏，原料温度压力料位显示直观，
All high pressure foaming machine use the 10 inch touch screen, Raw material temperature and pressure level display intuitive



所有高压发泡机都采用变频器控制，省电在30%以上
All high pressure foaming machine adopts frequency converter control, save electricity above 30%



客户案例 Customer case

直线式自动发泡线 Linear automatic foaming line

该发泡线由预热烘炉、动力滚筒线、进箱90°转相机（含箱体识别）、双向运载系统（可含自动充氮装置）、发泡夹具、自动充注系统、出箱顶升平移机、外膜外加热系统以及配套气动系统、电控系统等部分组成。

The foaming line by the preheat oven, dynamic drum line, into the box 90. Turn the camera (including body recognition) and bidirectional delivery systems (including automatic nitrogen inflator device), Foaming clamp, automatic filling system, outside the box top dressing switching, outer membrane heating system and pneumatic system and electric control system and other parts.

该发泡线采用直线式布局，夹具外模采用模温机循环水加热。夹具具有自动堵泡和自动抽心功能，换模采用气缸或人工驱动连杆机构，有人工控制和电气控制双重自锁功能。适用于不同长、宽、高的箱体生产。生产线具有外形美观大方、结构经凑、环境污染少、劳动强度小、占地面积小、功能强、生产效率高、多品种柔性生产等特点。

The foaming line adopts linear layout, jig mold used mold temperature machine circulating water heating. Fixture with automatic blocking and automatic pumping heart function, adopt cylinder or changing of the mold Artificial driving linkage with manual control and electric control dual self-locking function. Is suitable for the production of boxes of different length, width and height. Production line with beauty of appearance View, by the pool structure, less environmental pollution, labor intensity is small, cover an area of an area small, strong function, high efficiency, many kinds of flexible production, etc.

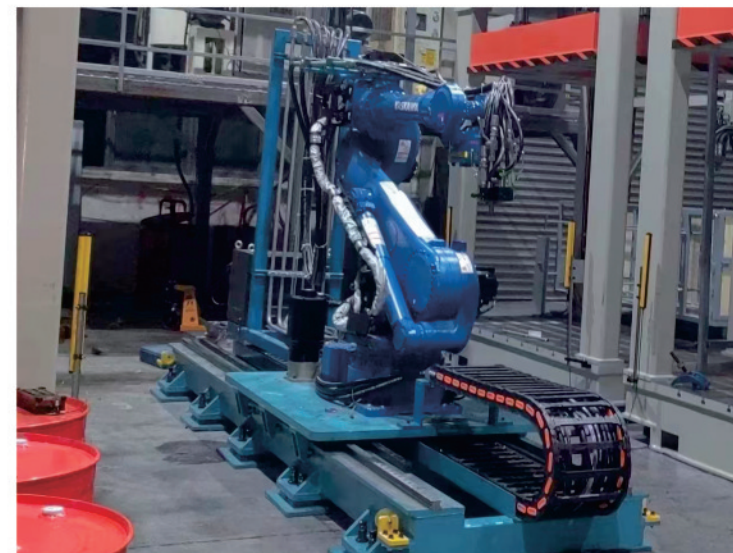

汽车地毯发泡 Car carpet foaming



汽车地毯发泡 Car carpet foaming



汽车头枕发泡 Car headrest foaming



汽车前围发泡 Automobile front wall foaming

客户案例 Customer case



太阳能发泡 Solar foaming



空气能发泡 Air foaming

客户案例 Customer case

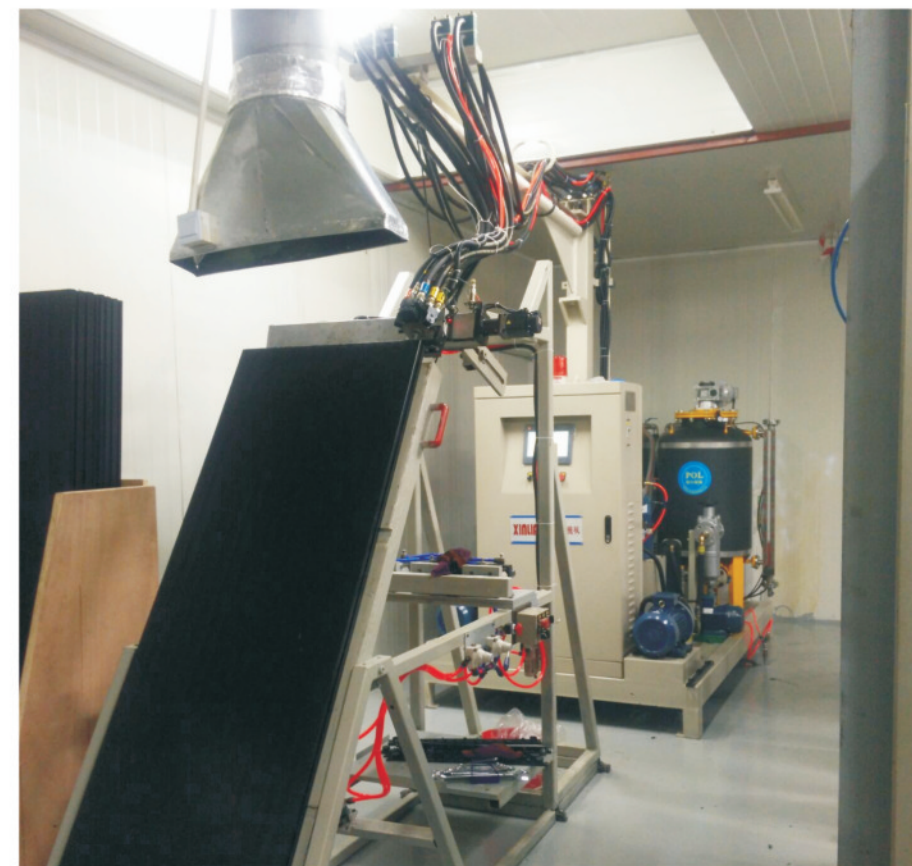

伺服电机控制混合头移动发泡
Servo motor control foam mixing head movement



发泡机移动式发泡
Foaming machine mobile foaming

客户案例 Customer case



冲浪板发泡 Foam surfboard

客户案例 Customer case



脚垫 Ottomans

客户案例 Customer case



防盗门发泡 Security door foaming

层压机 Laminating machine

客户案例 Customer case

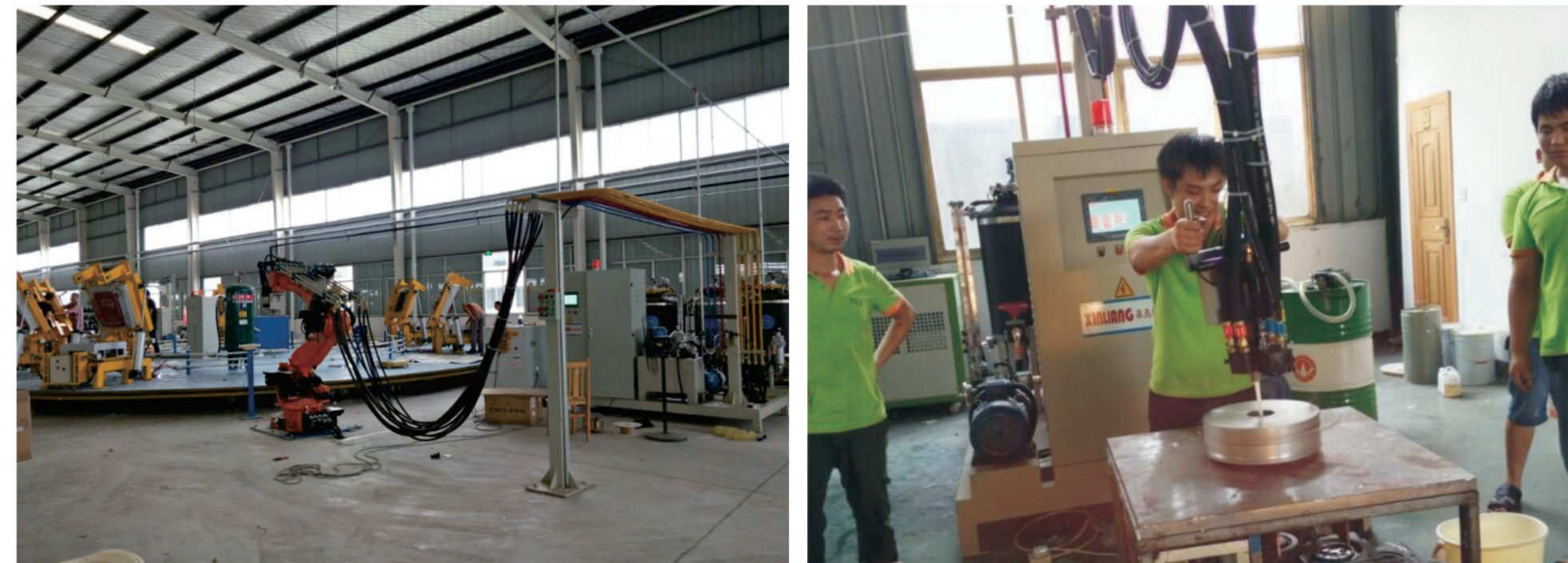

机械手自动发泡 Robot automatic foaming

童车PU轮发泡 PU foam wheel stroller

客户案例 Customer case



管道支架保温发泡 Pipe support insulation foam

客户案例 Customer case



汽车保险杠 Bumper

客户案例 Customer case



自动线连续板材发泡 Automatic line sheet continuous foaming

客户案例 Customer case



XY 轴自动浇注 XY axis automatic pouring

电热水器发泡 Electric water heater foaming

客户案例
Customer case

内外墙保温发泡 External insulation foam

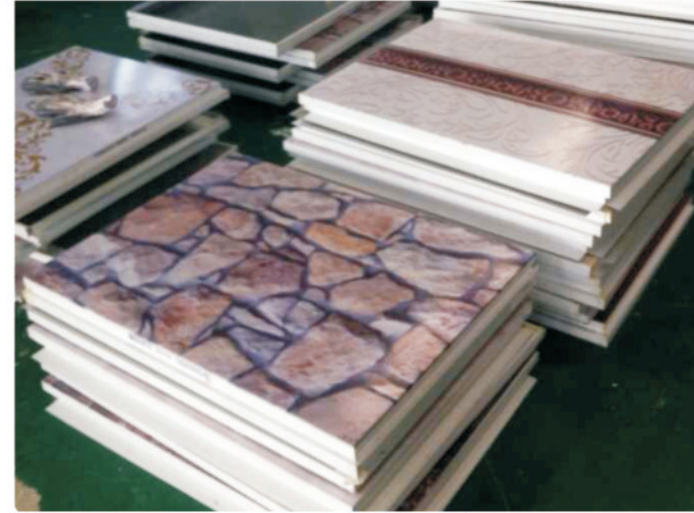

电地暖发泡 Electric floor heating foam



电地暖发泡 Electric floor heating foam

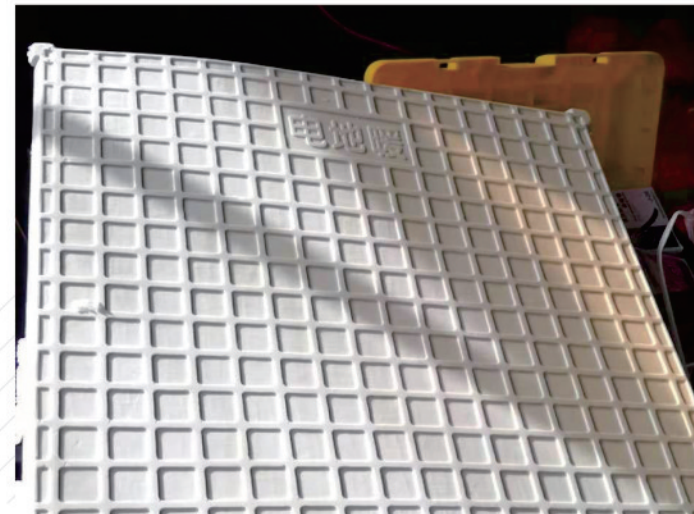

应用领域Application field:

汽车方向盘发泡Car steering wheel foaming



童车PU发泡轮
PU foam wheel stroller



健身器材座椅
Fitness equipment Seat



方向盘
steering wheel



汽车座椅
Car seat

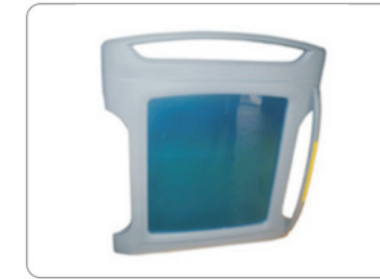

汽车扶手
Car armrest



汽车保险杠
The bumper



热水器
The water heater



太阳能
The solar energy



冰箱
refrigerator



冷柜
The freezer



消毒柜
Disinfection cabinet



保温板材
Insulation board

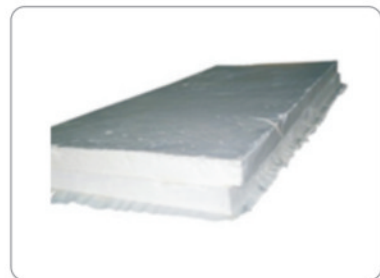

床垫
The mattress



头枕
headrest



防盗门
Guard against theft



厨房冰箱
The kitchen refrigerator



管道保温
Pipe insulation



装饰品
Adornment



管道保温
Pipe insulation



罗马柱
Roman column



装饰线条
The moulding



健身器材自结皮扶手
Fitness equipment since the
crust handrails



公司承诺Company Commitment

宁波鑫亮机械有限公司对售出设备整机保修一年，终身维修，长期提供技术咨询。免费负责对客户设备现场安装调试，培训操作及施工技术人员。设备如有故障，维修人员第一时间到达现场处理问题。配有各种设备零部件，一年质保期内由于质量问题造成的部件更换都由公司免费提供。

Ningbo xin bright company to sell equipment machine one year warranty, life-long maintenance, provide technical advice for a long time. Responsible for the customer set free of charge For field installation and debugging, personnel training operation and construction technology. Equipment such as fault, maintenance personnel arrived at the scene processing asked the first time The topic. Equipped with all sorts of equipment parts and components, one year warranty period due to quality problems caused by the parts replacement is provided free of charge by the company.

服务承诺在紧急情况下接到贵公司电话

宁波地区**1小时**内到达现场

珠三角地区**2小时**内到达现场

华东地区**4小时**内到达现场

华南地区**4小时**内到达现场

其它省份地区**24小时**内到达现场

24小时售后服务电话:13645840222 0574-62853033